

Quilting the Kaye Wood Way!

Quilt Binding with Kaye's Perfect Mitered Corners

Kaye prefers using a double binding and a binding cut on the straight of grain unless there are curves, then a bias binding should be used.

1. The finished width of the binding (the width shown on the right side of the quilt) determines the width of the binding strip.

2. Cut the binding strips 6 times the finished width, except for a finished width of $\frac{1}{4}$ ".

$\frac{1}{4}$ " finished width	cut strips $1\frac{3}{4}$ " wide
$\frac{1}{2}$ " finished width	cut strips 3" wide
$\frac{3}{4}$ " finished width	cut strips $4\frac{1}{2}$ " wide
1" finished width	cut strips 6" wide

3. Place the strips right sides together at right angles. Sew diagonally across the ends of the strips. Press the seam allowances open.

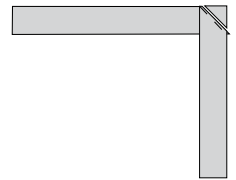

4. Fold the strip in half lengthwise, wrong sides together.



5. Place the binding strip to the middle of one side of the front of the quilt. Leaving a 10" tail at the beginning, sew the binding strip to the quilt top.

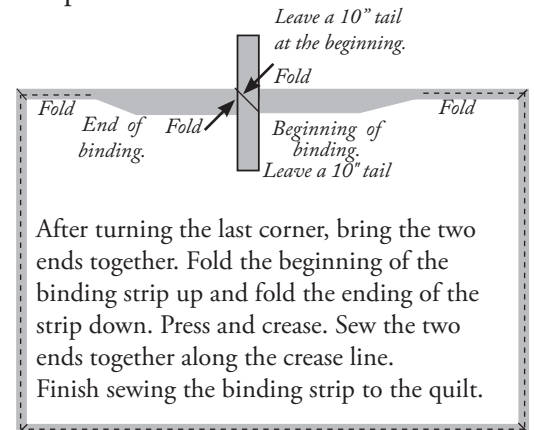
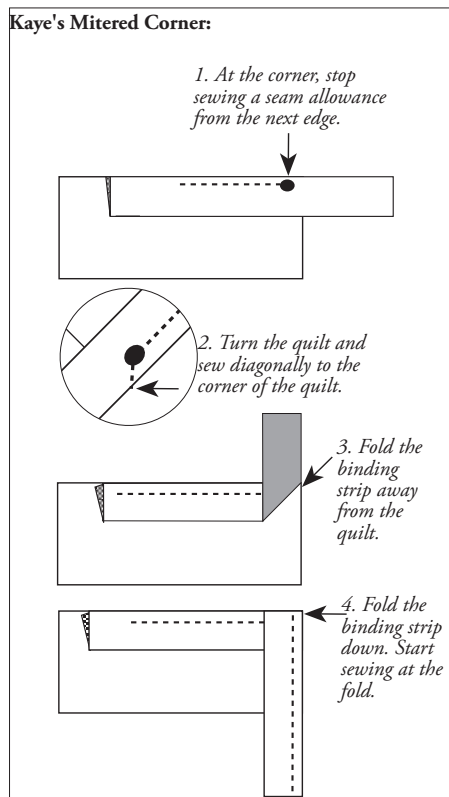

check the other free Tip Sheets at
www.kayewood.com
FREE videos at www.kayewoodTV.com
call 1-800-248-5293 to request a catalog